

Mathematica Centrum

Together, let's shape the mathematicians of the future

LAGRANGE PREPARATORY TEST 2025

- Which of the numbers below does not give a perfect square when we add 5 to it?
 A) 31 B) 14 C) 20 D) 11 E) 4
- Which number has 7 factors?
 A) 12 B) 24 C) 48 D) 30 E) 64
- If $0.2 \times n^2 = 8$, then n is equal to
 A) $2\sqrt{5}$ B) $2\sqrt{10}$ C) $4\sqrt{5}$ D) 4.5 E) 5.5
- All natural numbers between 0 and 100 are written on balls and placed in a lottery drum. What is the probability that the randomly selected ball will display a number that is a multiple of 4?
 A) $1/4$ B) $6/25$ C) $8/33$ D) $7/26$ E) $12/49$
- If $x\%$ of 30 is 12, then $2x\%$ of 95 is equal to
 A) 76 B) 72 C) 76 D) 74 E) 78
- The product of two natural numbers is 24. Their largest possible sum is equal to
 A) 11 B) 12 C) 10 D) 25 E) 14
- In an election, Melissa received 10 votes, Andrea received 9 votes, Carol, 3 votes, and Theo, 14 votes. Which of the pie graphs shown below best represents the distribution of votes?

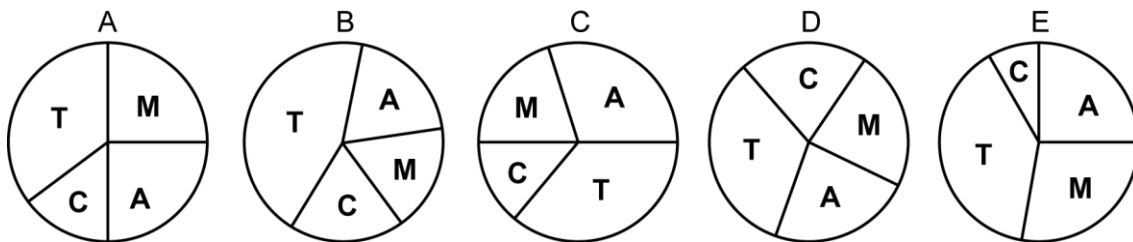

8. Eight blocks were glued together as shown in the diagram. How many faces of these blocks are covered with glue?

- A) 14 B) 16 C) 18
 D) 20 E) 22

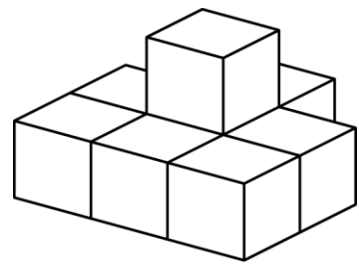

9. What fraction is the average of $\frac{1}{4}$ and $\frac{1}{2}$?

- A) $\frac{5}{16}$ B) $\frac{3}{11}$
 C) $\frac{3}{8}$ D) $\frac{1}{3}$
 E) $\frac{4}{9}$

10. Join the dots whose coordinates are A (-3, 2), B (3, 2), C (3, 0) and D (-3, 0). The polygon ABCD is a

- A) rectangle B) trapezium
 C) square D) rhombus
 E) parallelogram

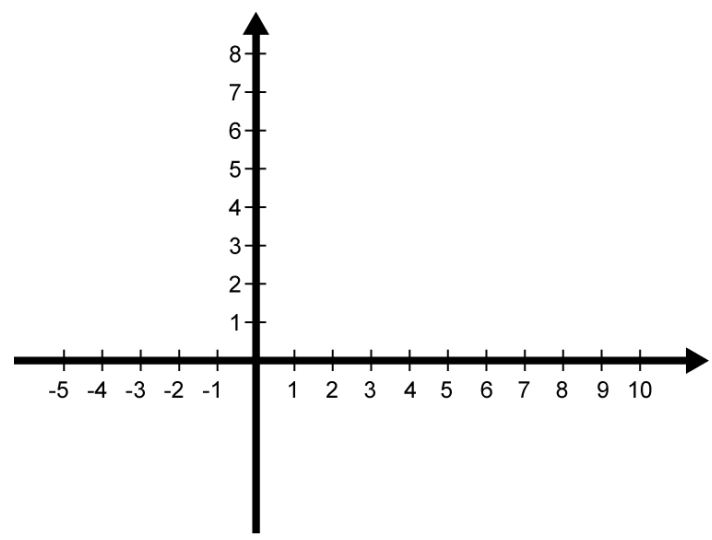

11. If $6 * 3 = 12$, $9 * 9 = 27$, $12 * 4 = 20$ and $8 * 3 = 14$, then $9 * 1 = ?$

- A) 7 B) 8
 C) 9 D) 10
 E) 11

12. ABC is a right-angled Δ (angle ABC is equal to 90°). What is the area of ΔACB ?

- A) 9 B) $\frac{9\sqrt{3}}{2}$
 C) $9\sqrt{3}$ D) $\frac{9\sqrt{2}}{2}$
 E) $9\sqrt{2}$

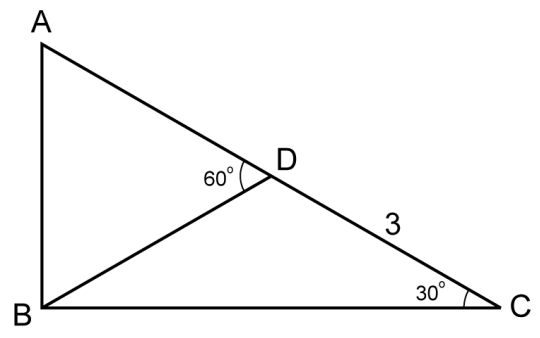

13. The Syracuse conjecture (also known as the Collatz conjecture or $3n + 1$ conjecture) states that if you apply two arithmetic operations repeatedly (division by 2 or $3n + 1$) on any natural positive number greater than 1, you create a sequence or string of natural numbers that always reaches 1. This conjecture has never been proven, but it has never been contradicted. Let's use the number 5 as an example. If the number is even, we divide by 2; if it is odd, multiply by 3 and add 1. The number 5 being odd, we multiply it by 3 and add 1. We get $(3 \times 5 + 1)$ 16. The number 16 being even, we divide by 2 and obtain $(16 \div 2)$ 8. We repeat the same operation (division by 2) three more times and we reach 1. The length of the string of numbers for 5 is (5, 16, 8, 4, 2, 1) 6. What is the string length for the number 20?

- A) 5 B) 6 C) 7 D) 8 E) 9

14. You have a cube whose edges measure 1 m. You cut it into cubes whose edges measure 1 dm. If it were possible to stack these cubes on top of each other to form a vertical tower, what would the height of this tower be?

- A) 100 m B) 100 dm C) 1 m D) 10 km E) 1 000 m

15. The LCM and GCD of 12 and 18 are respectively
- A) 36 and 6 B) 12 and 36 C) 36 and 12 D) 72 and 12 E) 24 and 12

16. A small staircase leads to a podium. The steps are of equal heights and equal depths. All of the edges that meet are perpendicular to each other. What is the area of the two lateral faces (the irregular octagonal figures on the sides) of this staircase?

- A) 1 m^2 B) 5 m^2
 C) 2 m^2 D) 4 m^2
 E) 3 m^2

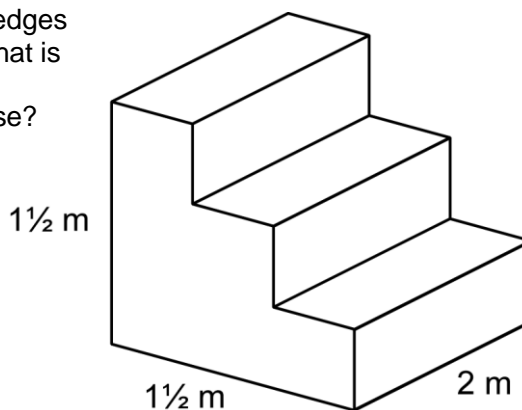

17. If $x = -1$, the value of $2x^2 + 5$ is

- A) 3 B) 4
 C) 5 D) 7
 E) 6

18. A recipe calls for 500 grams of flour for 4 eggs. Approximately how many grams of flour will we need to use for 6 eggs?

- A) 780 g B) 720 g C) 750 g D) 800 g E) 850 g

19. The sum of 24 consecutive integers is -12. If the smallest is -12, which is the largest?

- A) 13 B) 9 C) 11
 D) 12 E) 10

20. A cube has edges that measure 5 centimeters. What is the length of the space diagonal AB shown in bold type in the diagram?

- A) 9 cm B) $5\sqrt{2}$ cm C) $10\sqrt{2}$ cm
 D) $5\sqrt{3}$ cm E) $10\sqrt{3}$ cm

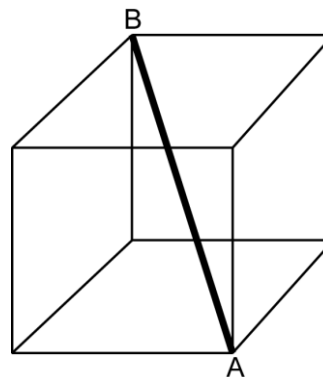

21. A gear is made of two cog-wheels. The wheel on the right is made up of 8 teeth while the left one has 9 teeth. The 8-tooth wheel rotates in the direction indicated by the arrow and controls the movement of the other wheel. The 3 teeth meshed in the diagram are 3F4. Which teeth will mesh together, if the 8-tooth wheel makes two complete revolutions?

- A) 4F5 B) 3G4 C) 5E6
 D) 5F6 E) 6F7

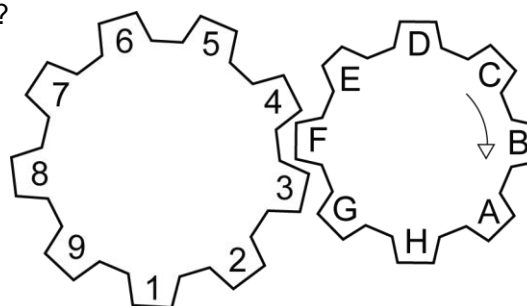

22. If M is a natural number, which of the numbers below could be equal to $3M + 6$?

- A) 221 B) 186 C) 155
 D) 160 E) 308

23. Four congruent circles of radius 2 are tangent to each other. What is the length of the line that circumscribes the 4 circles?

- A) $4\pi + 20$ B) $2\pi + 16$ C) $4\pi + 16$
 D) $4\pi + 12$ E) $2\pi + 20$

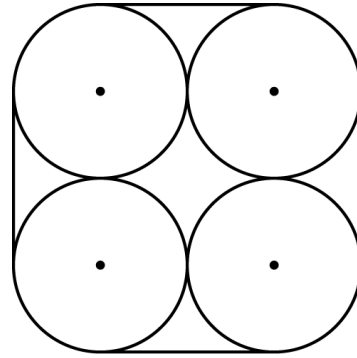

24. The measures of the 3 angles of a triangle are in the ratio 4 : 5 : 6. What is the value of the largest angle?

- A) 68° B) 72° C) 60°
 D) 84° E) 75°

25. The theoretical probability of getting heads (or tails) when a coin is flipped 1 time is $1/2$. The probability of getting 2 tails (or 2 heads) if the coin is flipped 2 times is $(1/2)^2$. If a coin is flipped 4 times, what is the probability that we will get 4 heads?

- A) $3/16$ B) $15/16$ C) $1/4$ D) $1/8$ E) $1/16$

26. The numbers q and r are two natural numbers. If q has 8 prime factors and r has 6 prime factors, how many prime factors does the product $q \times r$ have?

- A) 14 B) 10 C) 16 D) 18 E) 12

27. The area of square $MNOP$ is 9. MQO is a quarter-circle and PN is a diagonal. What is the length of line segment QN ?

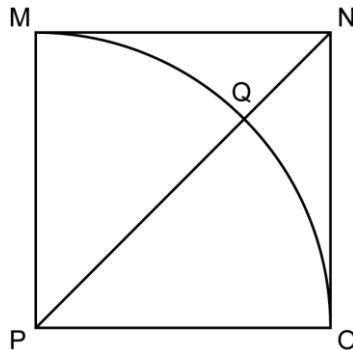

- A) $2\sqrt{2} - 3$ B) $3(\sqrt{2} - 1)$ C) $3/\sqrt{2}$ D) 3 E) $3\sqrt{2} - 2$